

WIRING INSTRUCTIONS

TITLE

ORBITAL SANDERS

**BULLETIN
58-01-0470**

MILWAUKEE ELECTRIC TOOL CORP.

13135 WEST LISBON RD. BROOKFIELD, WIS.

Date
Nov. '69

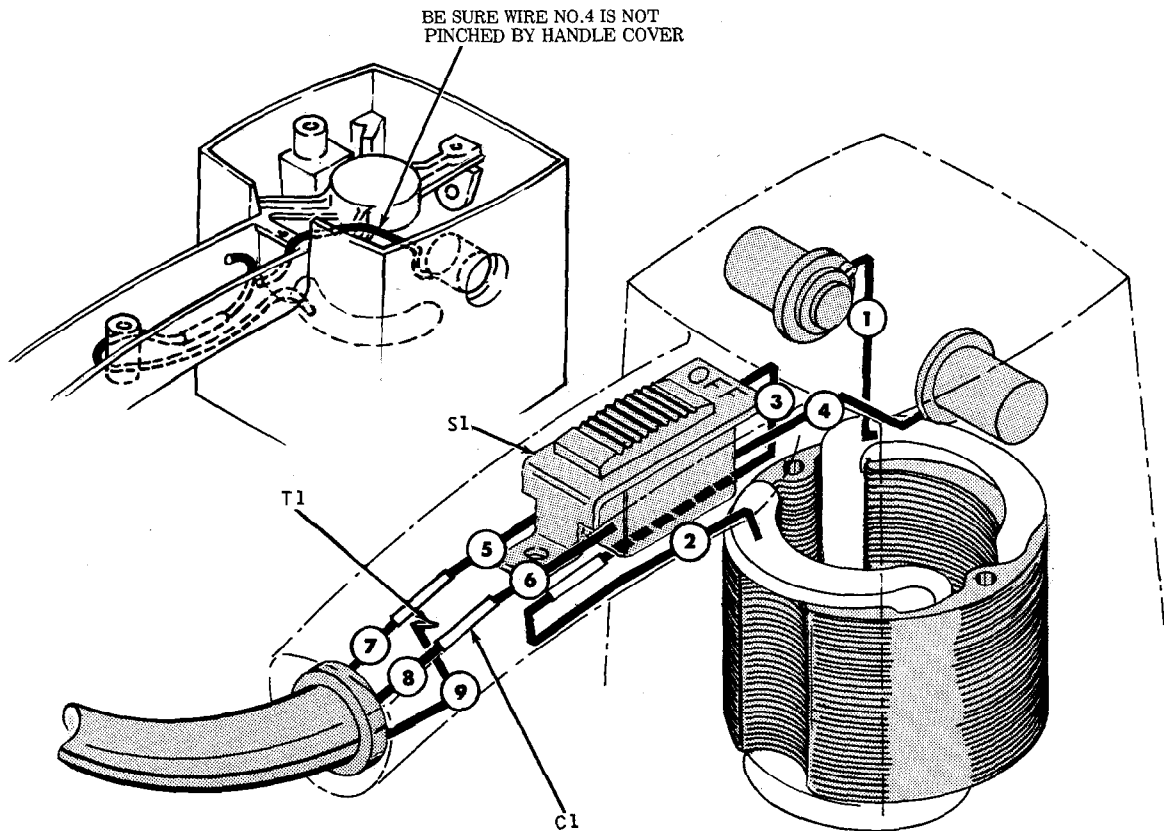

NOTE:
ALL LEADS MUST BE HELD TO ± 1/8"
ALL FIELD LEADS TO BE MEASURED FROM
AND PERPENDICULAR TO LAMINATIONS.
ALL LEAD LENGTHS ARE BEFORE STRIPPING.

WHERE TERMINAL AND CONNECTOR COMBINATIONS ARE SPECIFIED, SEE ELECTRICAL PARTS CHART
FOR PART NO. AND QUANTITY AND DRAWING FOR ACTUAL HOOK-UP

WIRING SPECIFICATIONS

Wire Color	Wire No.	Ga.	Lgth. in.	Terminal				Connector				Wire Color	Wire No.	Ga.	Lgth. in.	Terminal				Connector							
				T1	T2	T3	T4	C1	C2	C3	C4					T1	T2	T3	T4	C1	C2	C3	C4				
Red	1	Fld.	2-3/4									Black	7	Cord	2									X			
Brown	2	Fld.	5					X				White	8	Cord	2												X
												Green	9	Cord	2	X											
Black	3	Swit.	2-5/8																								
Black	4	Swit.	2-5/8																								
Black	5	Swit.	1-3/4																								
Black	6	Swit.	1-3/4																								

Electrical Parts		
TERMINAL DESCRIPTION		
Code	Part No.	Qty.
T1	23-74-0050	1
CONNECTOR DESCRIPTION		
Code	Part No.	Qty.
C1	23-74-0080	3
SWITCH DESCRIPTION		
Code	Part No.	Qty.
S1	23-66-0380	1